

NOTE -  
 WALLS OF BASIN MAY BE  
 BRICK OR C.M.U. (8" THICK)  
 OR POURED CONCRETE (6"  
 THICK) OR PRECAST  
 CONCRETE (5" THICK). IF OF  
 BRICK OR C.M.U., WALLS SHALL  
 BE PARGED WITH 1/2" CEMENT  
 MOTAR, INSIDE AND OUTSIDE.

SECTION B-B

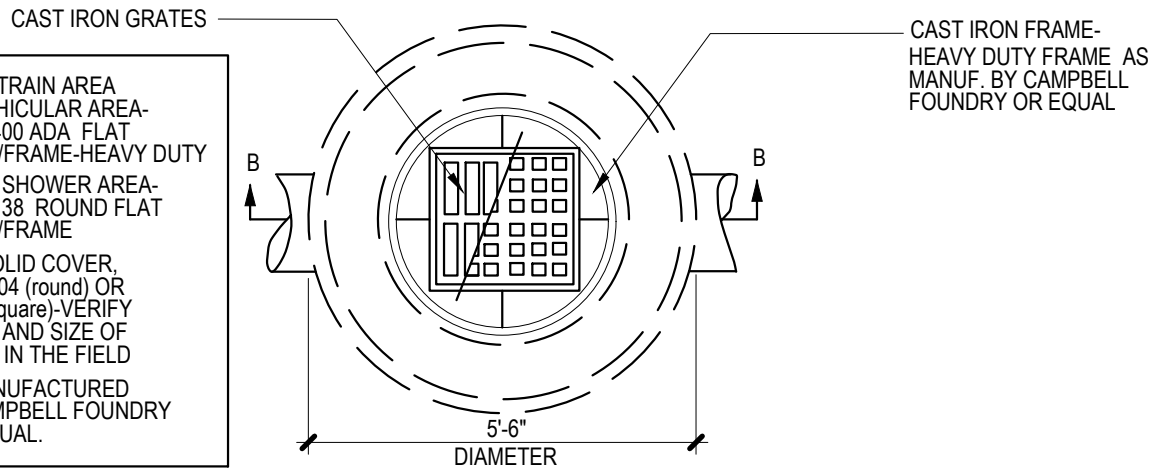

PEDESTRAIN AREA  
 and VEHICULAR AREA-  
 2815 1400 ADA FLAT  
 GRATE/FRAME-HEAVY DUTY  
 SPRAY SHOWER AREA-  
 4129 0138 ROUND FLAT  
 GRATE/FRAME  
 FOR SOLID COVER,  
 USE 1204 (round) OR  
 2803 (square)-VERIFY  
 SHAPE AND SIZE OF  
 FRAME IN THE FIELD  
 AS MANUFACTURED  
 BY CAMPBELL FOUNDRY  
 OR EQUAL.

PLAN



New York City Housing Authority  
 Capital Projects Division  
 Design Department  
 90 Church Street, 10th Floor  
 New York, NY 10007

Title:

**CATCH BASIN / MANHOLE  
 NEW OR EXISTING PIPE**

Contract Name:

**GROUNDS REQUIREMENT**

Contract No.

**GD XXXXXXX**

Drawn by:

**G. SOUKAS**

Checked by:

**K. MARSHAL**

Scale:

**Not to Scale**

Date:

**January 2017**

Drawing No.

**PLU- 01**