

PLAN VIEW

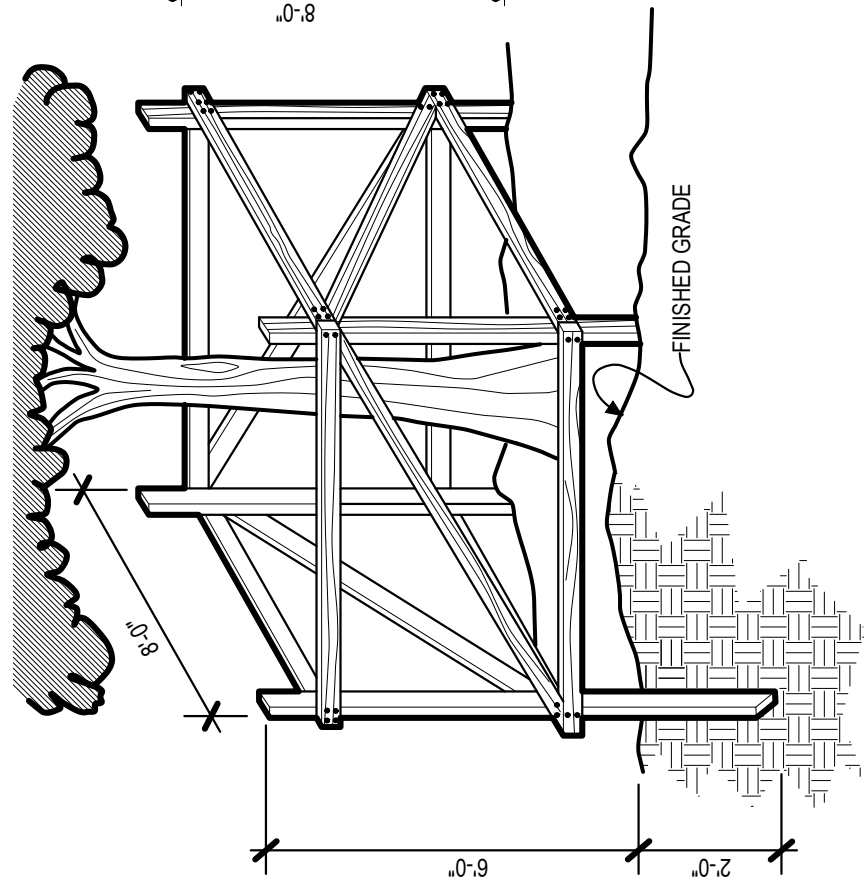

New York City Housing Authority
 Capital Projects Division
 Design Department
 90 Church Street, 10th Floor
 New York, NY 10007

Title:
TEMPORARY WOODEN TREE GUARD

Contract Name:
GROUNDS REQUIREMENT

Contract No.
 GD XXXXXXXX

Drawn by:
 G. SOUKAS

Checked by:
 K. MARSHAL

Scale:
 Not to Scale

Date:
 January 2017

Drawing No.
STP- 01