

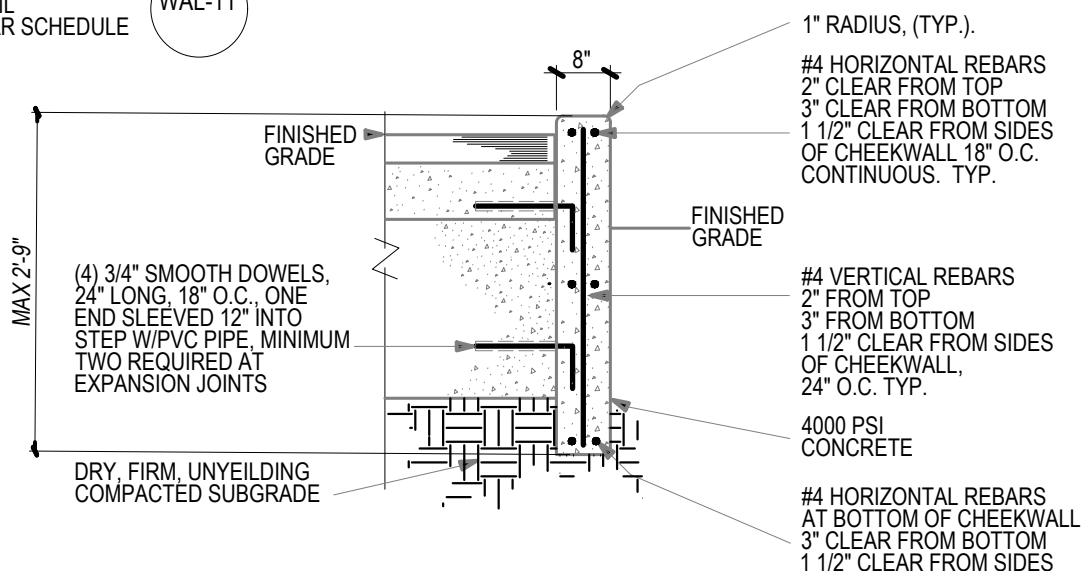

STEP SECTION

NOTE:
SEE DETAIL
FOR REBAR SCHEDULE

WAL-11



CHEEKWALL SECTION

 <p>New York City Housing Authority Capital Projects Division Design Department 90 Church Street, 10th Floor New York, NY 10007</p>	Title:		<p>CONCRETE STEP AT ENTERANCE</p>	
	Contract Name:	Contract No.		
<p>GROUNDS REQUIREMENT</p>	<p>GD XXXXXX</p>	<p>Not to Scale</p>	<p>WAL- 05</p>	
	<p>Drawn by: G. SOUKAS</p>	<p>Checked by: K. MARSHAL</p>		<p>Date: January 2017</p>