

**ELEVATION**

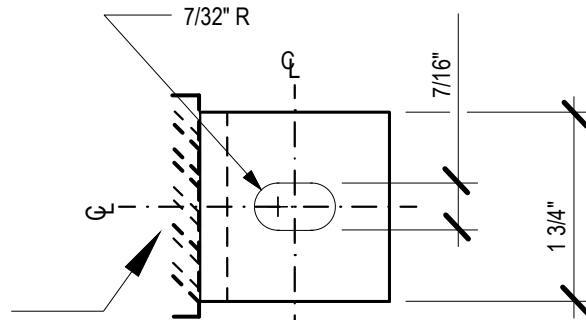

**PLAN**

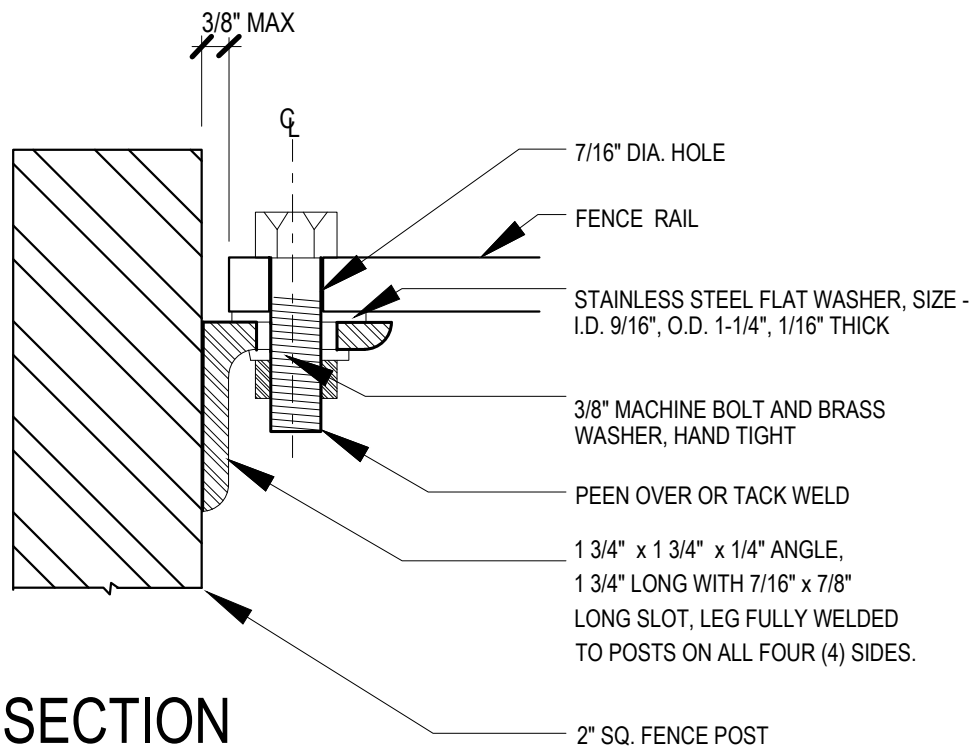

**SECTION**



New York City Housing Authority  
 Capital Projects Division  
 Design Department  
 90 Church Street, 10th Floor  
 New York, NY 10007

Title:

**ANGLE & BOLT  
 for 6' Steel Bar Fence**

Contract Name:

**GROUNDS REQUIREMENT**

Contract No.

**GD XXXXXXX**

Drawn by:  
**G. SOUKAS**

Checked by:  
**K. MARSHAL**

Scale:

**Not to Scale**

Date:

**January 2017**

Drawing No.

**SBF- 26**