

THE ACCESSIBILITY SYMBOL SHALL BE PAINTED ON THE PAVEMENT OF THE PARKING STALL AS SPECIFIED ON THE PLANS AND IN ACCORDANCE WITH THE "AMERICAN NATIONAL STANDARDS INSTITUTE". COLOR SHALL BE BLUE. SEE ASPHALT SPECIFICATIONS.

SYMBOL PROPORTIONS

SYMBOL SHALL CONTRAST WITH ITS BACKGROUND-EITHER LIGHT SYMBOL ON DARK PAVEMENT (ASPHALT) OR DARK SYMBOL ON LIGHT PAVEMENT (CONCRETE)

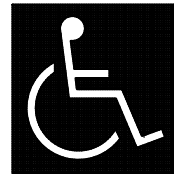

SYMBOL DISPLAY CONDITIONS

VANDAL PROOF BOLT, TYPICAL. SECURE SIGN TO FENCE WITH GALVANIZED STEEL STRAPS. TOP STRAP SHALL BE AROUND TOP RAIL OF FENCE, BOTTOM STRAP SHALL BE AROUND VERTICAL FENCE PICKET.

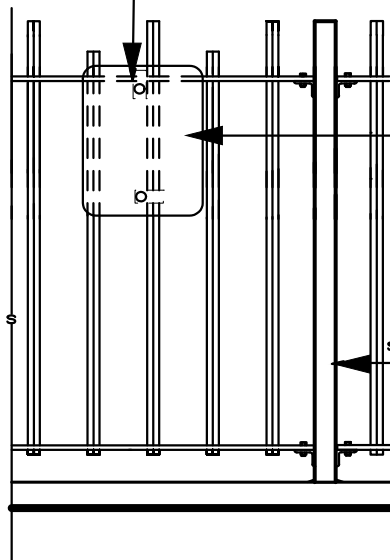

ACCESSIBLE PARKING SIGN "SS56" 12" X 18" (STEEL) BY BEST SIGN SYSTEMS, MONTROSE, CO. (970)249-0223 OR APPROVED EQUAL.

STEEL BAR FENCE

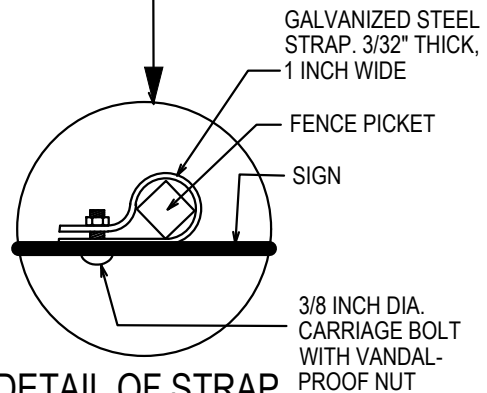

DETAIL OF STRAP
N.T.S.

SIGN MOUNTING



New York City Housing Authority
Capital Projects Division
Design Department
90 Church Street, 10th Floor
New York, NY 10007

Title: ***FENCE-MOUNTED SIGN and SYMBOL for Accessible Parking Space***

Contract Name:

GROUNDS REQUIREMENT

Contract No.

GD XXXXXXX

Drawn by:
G. SOUKAS

Checked by:
K. MARSHAL

Scale:

Not to Scale

Date:

January 2017

Drawing No.

AME- 12